

# Zigbee to DALI+0/1-10V 2 in 1 Converter

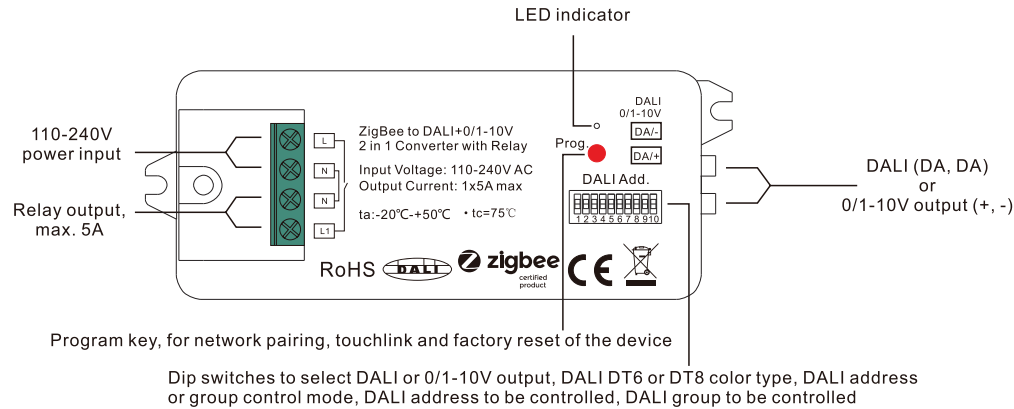

**Important:** Read All Instructions Prior to Installation

## Function introduction



## Product Data

Input		Output, DALI		Output, 0/1-10V	Output, relay		Environment		Others
Power	Signal	DALI PS current	DALI current consumption	Current	Switching voltage	Max. Current	Operating temperature	Relative humidity	Dimensions
110-240VAC	Zigbee 2.4GHz	Max. 50mA	Max. 4mA	Max. 20mA	110-240VAC	Incandescent: 5A LED: 1.6A	-20°C~+50°C	8% to 80%	95x37x20mm

- Zigbee to DALI+0/1-10V 2 in 1 converter based on zigbee 3.0
- Zigbee signal input, DALI signal output to DALI line or 0/1-10V signal output, 110-240VAC power input
- With relay output, max. 5A for traditional incandescent & HV halogen lamps, max 1.6A for LED load
- Compatible with universal Zigbee gateway or hub products
- Can directly pair to a compatible ZigBee remote via Touchlink
- Compatible with universal Zigbee remotes
- Supports self-forming zigbee network without coordinator
- Supports find and bind mode to bind a ZigBee remote
- Supports zigbee green power and can bind max. 20 zigbee green power remotes
- DALI signal or 1-10V signal output selectable by DIP switch
- Built-in DALI bus power supply, no extra DALI bus PS required
- With max. 50mA DALI bus power current output
- To supply control current to up to 25 DALI control gears
- DALI DT6 or DT8 device type selectable by DIP switch under DALI mode
- Color control according to DALI specifications of Device Type 8,
- Color type: Tc, XY coordinates, RGBW selectable by DIP switches
- DALI address control mode or group control mode selectable by DIP switch

- Enables to select the DALI address (00-63) to be controlled by DIP switches
- Enables to select the DALI group (0-15) to be controlled by DIP switches
- Enable to control 1 DALI Group of devices or 1 DALI Address on DALI line
- Enable to control all devices on DALI line via broadcast
- Waterproof grade: Ip20

## Safety & Warnings

- DO NOT set the DIP switches with power applied to the device.
- DO NOT install with power applied to device.
- DO NOT expose the device to moisture.

## Operation

### 1) Select DALI or 0/1-10V Output Using Dial Switch 10

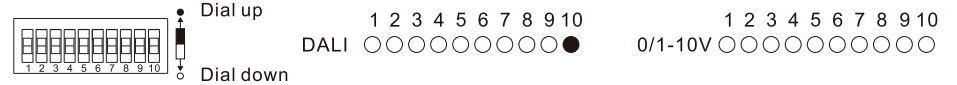

**Note:** please first select output signal by the dial switch.

### 2) Select DALI Device Type (DT6/DT8 Color Type) to be Controlled Using Dial Switches 8-9



**Note:** once DALI output is selected, please then select the DALI device type you would like to control by the dial switches.

### 3) Select DALI Address or Group Control Mode Using Dial Switch 7



**Note:** once DALI device type is selected, please then select address control mode or group control mode by dial switch.

### 4) Select the DALI Group to be Controlled Using Dial Switches 2-6

**Note:** here device type is selected as DIM as an example, please select your correct DALI device type.

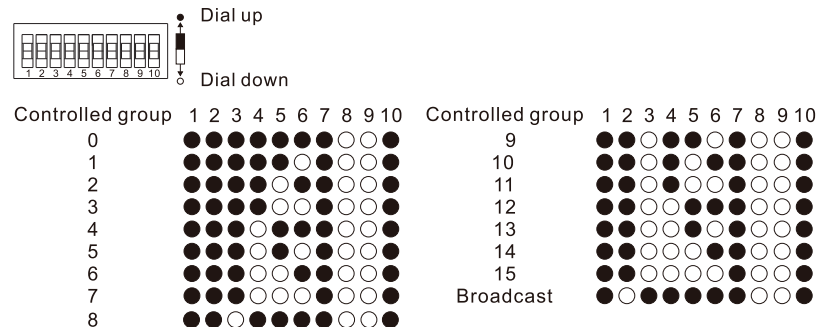

- Note:**
- 1) once DALI device type and group control mode are selected, please then select the DALI group (0-15 selectable) to be controlled on DALI line by dial switches.
  - 2) The control gears that are assigned to the selected DALI group on DALI line will be controlled.
  - 3) The control gears shall be first grouped by a DALI master controller, please refer to the user manual of corresponding master controller.

### 5) Select the DALI Address to be Controlled Using Dial Switches 1-6

Note: here device type is selected as DIM as an example, please select your correct DALI device type.

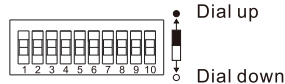

Controlled address	1	2	3	4	5	6	7	8	9	10	Controlled address	1	2	3	4	5	6	7	8	9	10	
00	●	●	●	●	●	○	○	○	○	○	32	○	○	○	○	○	○	○	○	○	○	○
01	●	●	●	○	○	○	○	○	○	○	33	○	○	○	○	○	○	○	○	○	○	○
02	●	●	○	○	○	○	○	○	○	○	34	○	○	○	○	○	○	○	○	○	○	○
03	●	●	○	○	○	○	○	○	○	○	35	○	○	○	○	○	○	○	○	○	○	○
04	●	○	○	○	○	○	○	○	○	○	36	○	○	○	○	○	○	○	○	○	○	○
05	●	○	○	○	○	○	○	○	○	○	37	○	○	○	○	○	○	○	○	○	○	○
06	●	○	○	○	○	○	○	○	○	○	38	○	○	○	○	○	○	○	○	○	○	○
07	●	○	○	○	○	○	○	○	○	○	39	○	○	○	○	○	○	○	○	○	○	○
08	●	○	○	○	○	○	○	○	○	○	40	○	○	○	○	○	○	○	○	○	○	○
09	●	○	○	○	○	○	○	○	○	○	41	○	○	○	○	○	○	○	○	○	○	○
10	●	○	○	○	○	○	○	○	○	○	42	○	○	○	○	○	○	○	○	○	○	○
11	●	○	○	○	○	○	○	○	○	○	43	○	○	○	○	○	○	○	○	○	○	○
12	●	○	○	○	○	○	○	○	○	○	44	○	○	○	○	○	○	○	○	○	○	○
13	●	○	○	○	○	○	○	○	○	○	45	○	○	○	○	○	○	○	○	○	○	○
14	●	○	○	○	○	○	○	○	○	○	46	○	○	○	○	○	○	○	○	○	○	○
15	●	○	○	○	○	○	○	○	○	○	47	○	○	○	○	○	○	○	○	○	○	○
16	●	○	○	○	○	○	○	○	○	○	48	○	○	○	○	○	○	○	○	○	○	○
17	●	○	○	○	○	○	○	○	○	○	49	○	○	○	○	○	○	○	○	○	○	○
18	●	○	○	○	○	○	○	○	○	○	50	○	○	○	○	○	○	○	○	○	○	○
19	●	○	○	○	○	○	○	○	○	○	51	○	○	○	○	○	○	○	○	○	○	○
20	●	○	○	○	○	○	○	○	○	○	52	○	○	○	○	○	○	○	○	○	○	○
21	●	○	○	○	○	○	○	○	○	○	53	○	○	○	○	○	○	○	○	○	○	○
22	●	○	○	○	○	○	○	○	○	○	54	○	○	○	○	○	○	○	○	○	○	○
23	●	○	○	○	○	○	○	○	○	○	55	○	○	○	○	○	○	○	○	○	○	○
24	●	○	○	○	○	○	○	○	○	○	56	○	○	○	○	○	○	○	○	○	○	○
25	●	○	○	○	○	○	○	○	○	○	57	○	○	○	○	○	○	○	○	○	○	○
26	●	○	○	○	○	○	○	○	○	○	58	○	○	○	○	○	○	○	○	○	○	○
27	●	○	○	○	○	○	○	○	○	○	59	○	○	○	○	○	○	○	○	○	○	○
28	●	○	○	○	○	○	○	○	○	○	60	○	○	○	○	○	○	○	○	○	○	○
29	●	○	○	○	○	○	○	○	○	○	61	○	○	○	○	○	○	○	○	○	○	○
30	●	○	○	○	○	○	○	○	○	○	62	○	○	○	○	○	○	○	○	○	○	○
31	●	○	○	○	○	○	○	○	○	○	63	○	○	○	○	○	○	○	○	○	○	○

Note: 1) once DALI device type and address control mode are selected, please then select the DALI address (00-63 selectable) to be controlled on DALI line by dial switches.  
2) The control gear with the selected DALI address on DALI line will be controlled.

### 6. ZigBee Clusters the device supports are as follows:

#### Input Clusters

- 0x0000: Basic
- 0x0003: Identify
- 0x0004: Groups
- 0x0005: Scenes
- 0x0006: On/off
- 0x0008: Level Control
- 0x0300: Color Control
- 0x0b05: Diagnostics

#### Output Clusters

- 0x0019: OTA

### 7. Do wiring according to connection diagram correctly.

8. This ZigBee device is a wireless receiver that communicates with a variety of ZigBee compatible systems. This receiver receives and is controlled by wireless radio signals from the compatible ZigBee system.

### 9. Zigbee Network Pairing through Coordinator or Hub (Added to a Zigbee Network)

Step 1: Remove the device from previous zigbee network if it has already been added to, otherwise pairing will fail. Please refer to the part "Factory Reset Manually".

Step 2: From your ZigBee Controller or hub interface, choose to add lighting device and enter Pairing mode as instructed by the controller.

Step 3: power on the device, it will be set into network pairing mode (connected light flashes twice slowly), the network pairing mode will last until the device is added to a zigbee network.

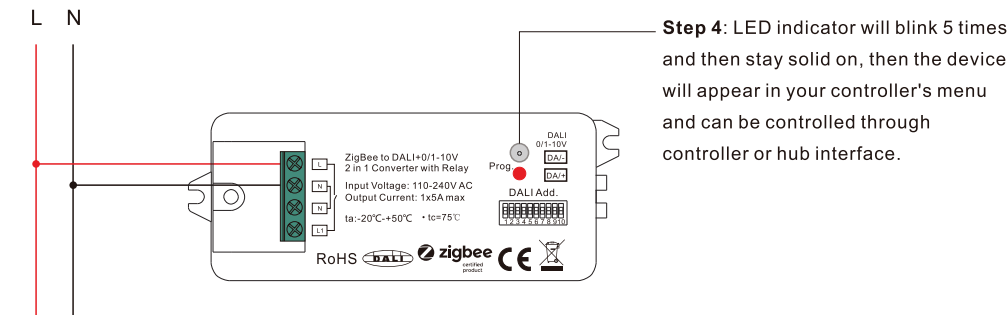

### 10. TouchLink to a Zigbee Remote

Step 1: Method 1: Short press "Prog" button 4 times (or reset power of the device 4 times) to start Touchlink commissioning immediately under any circumstances, which lasts for 180S, once time out, repeat this step.  
Method 2: Power on the device, whether the device has been added to a Zigbee network or not, it will be set into Touchlink commissioning immediately, Touchlink will last for 180S, once time out, reset power of the device to set it into touchlink commissioning again.

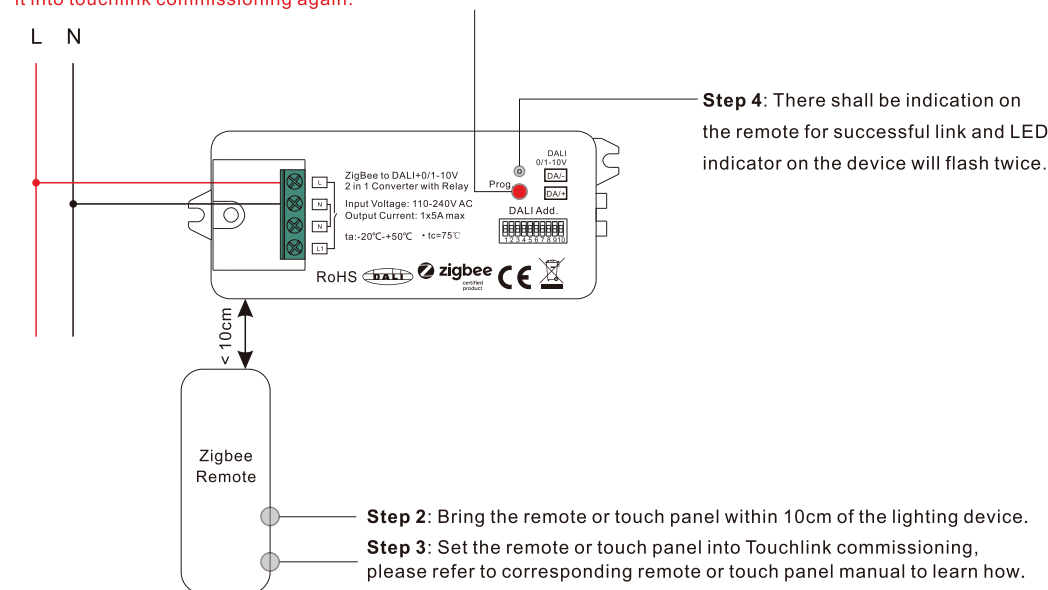

Note: 1) Directly TouchLink (both not added to a ZigBee network), each device can link with 1 remote.  
2) TouchLink after both added to a ZigBee network, each device can link with max. 30 remotes.  
3) To control through both gateway and remote, add remote and device to gateway network first then TouchLink  
4) After TouchLink, the device can be controlled by the linked remotes.

## 11. Removed from a Zigbee Network through Coordinator or Hub Interface

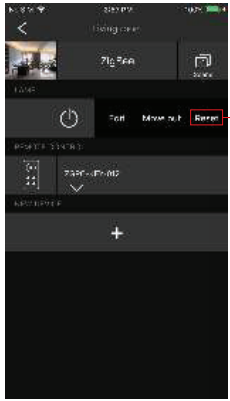

From your ZigBee controller or hub interface, choose to delete or reset the lighting device as instructed. The connected light blinks 3 times to indicate successful reset.

## 12. Factory Reset Manually

**Step 1:** Short press "Prog." key for 5 times continuously or reset power of the device for 5 times continuously from master breaker if the "Prog." key is not accessible.

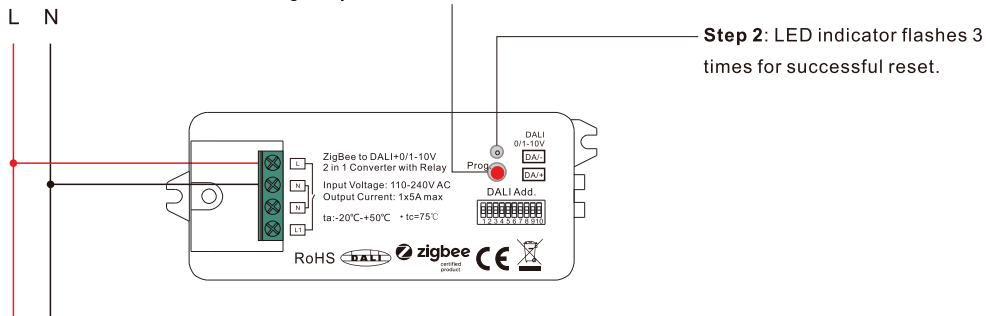

**Note:** 1) If the device is already at factory default setting, there is no indication when factory reset again.  
2) All configuration parameters will be reset after the device is reset or removed from the network.

## 13. Factory Reset through a Zigbee Remote (Touch Reset)

**Step 1:** Reset power of the device to start TouchLink Commissioning, 180 seconds timeout, repeat this step.

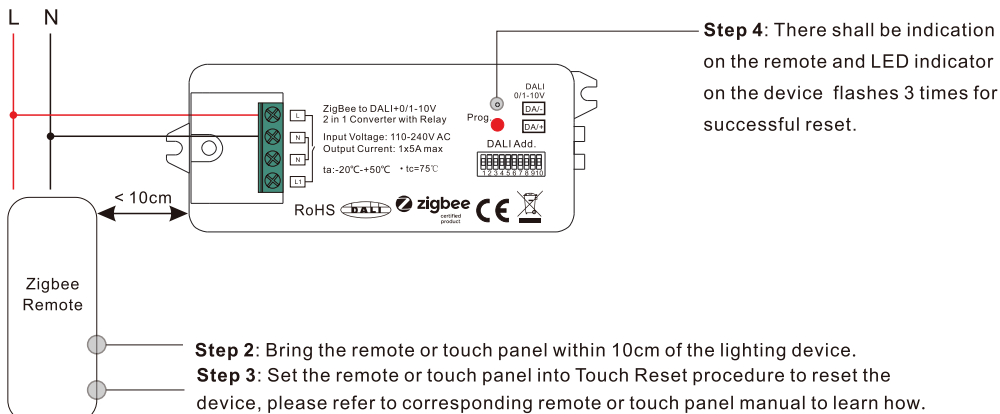

**Note:** Make sure the device already added to a network, the remote added to the same one or not added to any network.

## 14. Find and Bind Mode

**Step 1:** Short press "Prog." button 3 times (Or reset power of the device (initiator node) 3 times) to start Find and Bind mode (connected light flashes slowly) to find and bind target node, 180 seconds timeout, repeat the step.

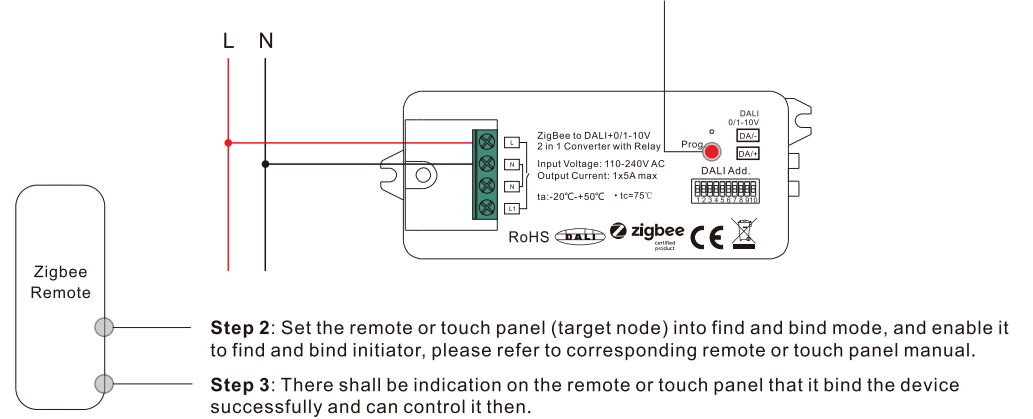

**Note:** Make sure the device and the remote or touch panel already added to the same Zigbee hub.

## 15. Learning to a Zigbee Green Power Remote

**Step 1:** Short press "Prog." button 4 times (Or reset power of the device 4 times) to start Learning mode (connected light flashes twice), 180 seconds timeout, repeat the step.

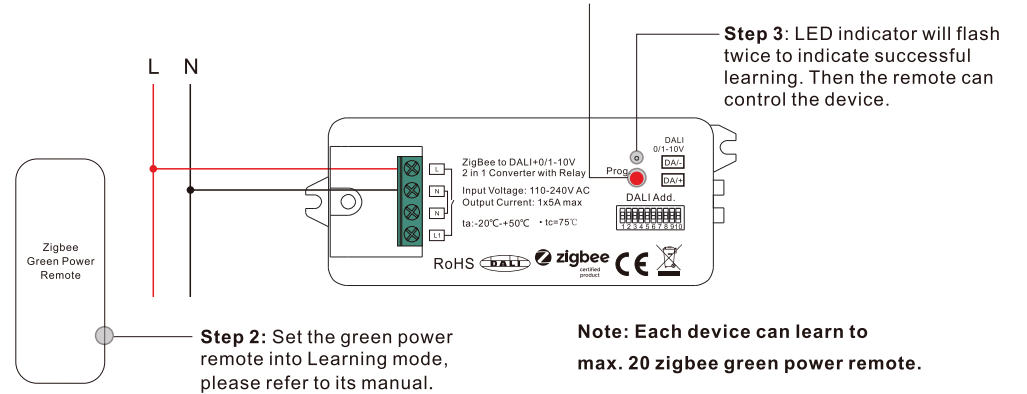

**Note:** Each device can learn to max. 20 zigbee green power remote.

## 16. Delete Learning to a Zigbee Green Power Remote

**Step 1:** Short press "Prog." button 3 times (Or reset power of the device 3 times) to start delete Learning mode (connected light flashes slowly), 180 seconds timeout, repeat the step.

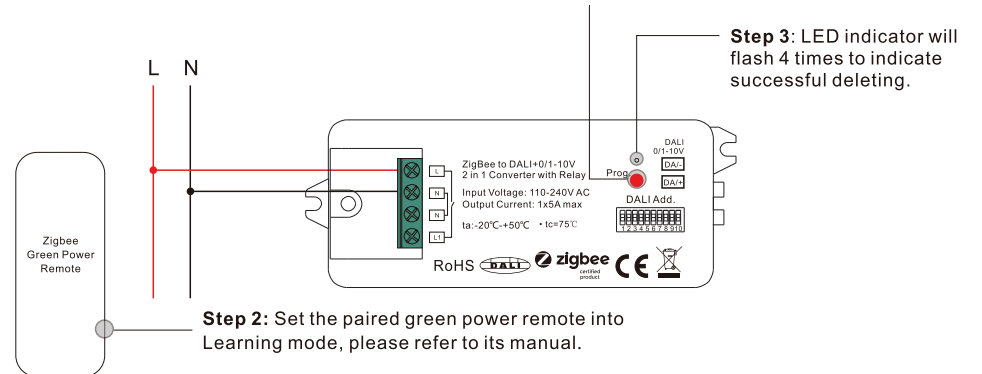

## 17. Setup a Zigbee Network & Add Other Devices to the Network (No Coordinator Required)

**Step 1:** Short press "Prog." button 4 times (Or reset power of the device 4 times) to enable the device to form a zigbee network (LED indicator flashes twice) to discover and add other devices, 180 seconds timeout, repeat the step.

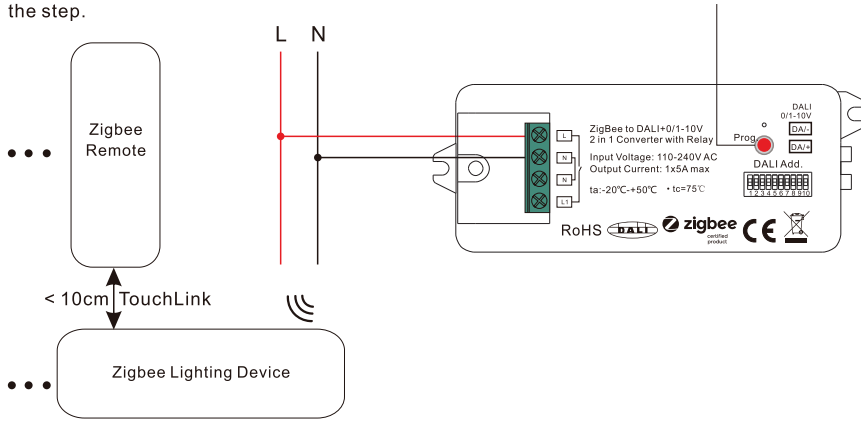

**Step 2:** Set another device or remote or touch panel into network pairing mode and pair to the network, refer to their manuals.

**Step 3:** Pair more devices and remotes to the network as you would like, refer to their manuals.

**Step 4:** Bind the added devices and remotes through Touchlink so that the devices can be controlled by the remotes, refer to their manuals.

**Note: 1)** Each added device can link and be controlled by max. 30 added remotes.

**2)** Each added remote can link and control max. 30 added devices.

## 18. OTA

The device supports firmware updating through OTA, and will acquire new firmware from zigbee controller or hub every 10 minutes automatically.

### Wiring Diagram

When 0/1-10V Output Selected

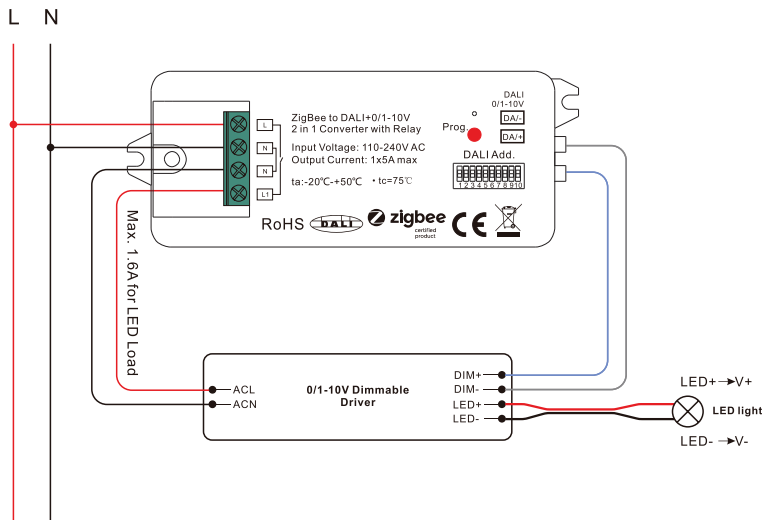

**Note:** the relay is only suggested to use when connected with 1-10V drivers which can not dim to off.

When DALI Output Selected

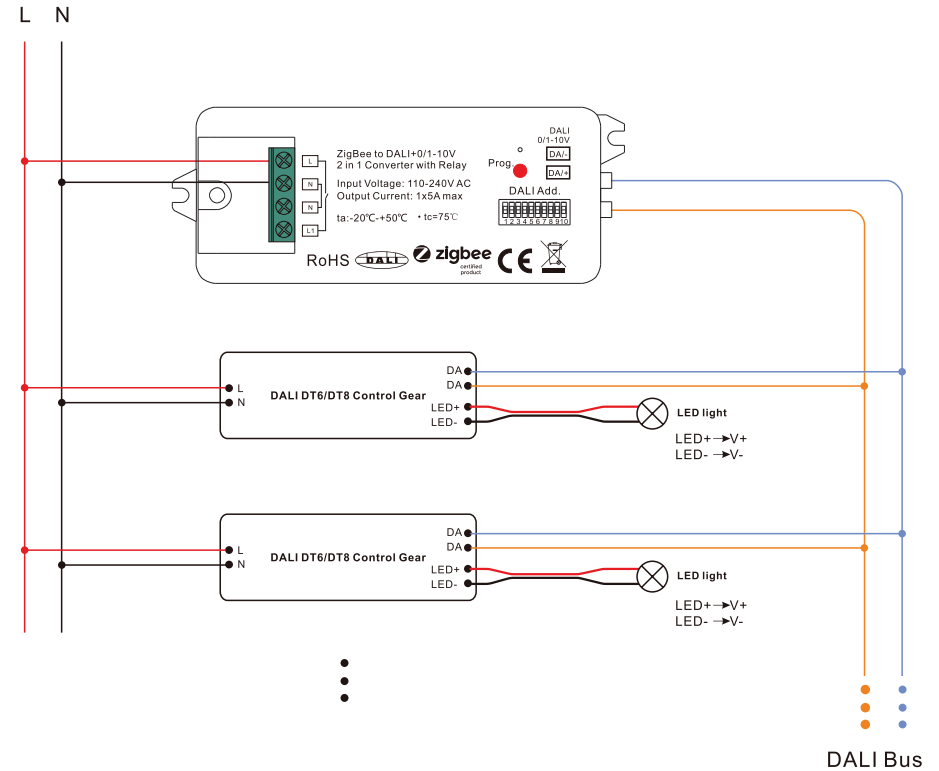

**Note:** Max. 50mA DALI bus PS output to supply control current to up to 25 control gears.

### Dimensions

