

Zigbee 4 In 1 Multi Sensor



Features

Key Features

- Zigbee 3.0 compliant
- PIR motion sensor, long detection range
- Temperature sensing, automates your home heating or cooling
- Humidity sensing, automates your home humidifying or dehumidifying
- Illuminance measuring, daylight harvesting
- Autonomous sensor-based control
- OTA firmware upgrade
- Wall mount installation
- Can be use for indoor applications

Benefits

- Cost-effective solution for energy savings
- Energy code compliance
- Robust mesh network
- Compatible with universal Zigbee platforms that support sensor

Applications

- Smart home

Product Description

The Zigbee sensor is a battery powered low power consumption 4 in 1 device that combines PIR motion sensor, temperature sensor, humidity sensor, and illuminance sensor. The PIR motion sensor trigger and sensitivity can be configured. The sensor supports low battery power alarm, if the power is lower than 5%, the motion sensor trigger and report will be forbidden, and the alarm will be reported every one hour until the battery power is higher than 5%. The sensor is suitable for smart home applications which need sensor based automation.

Commissioning

All setup is performed via supported IEEE 802.15.4-based control platforms and other Zigbee3.0 compatible lighting control systems. Appropriate gateway control software allows for adjustment of motion sensitivity, detection area, time delay and daylight threshold.

Product Info

Without Frame

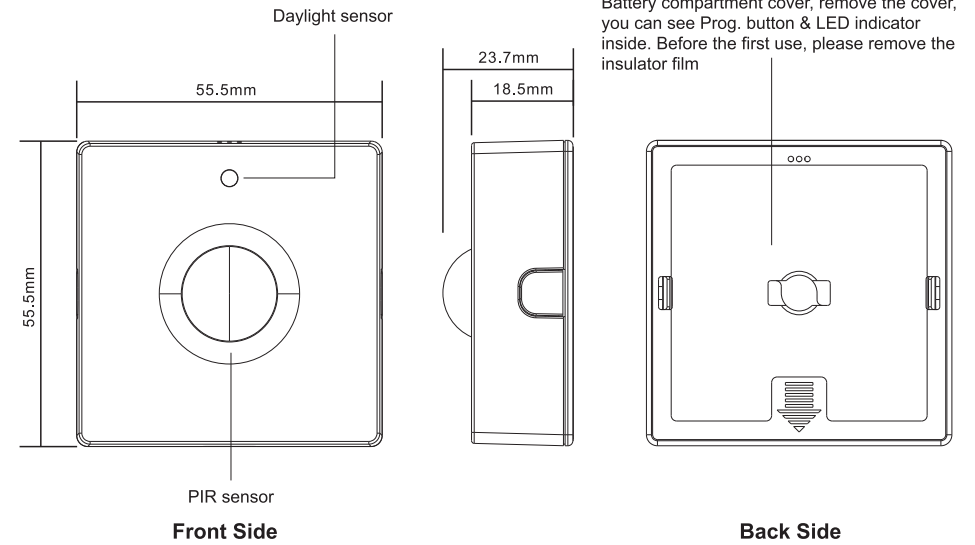

With Frame

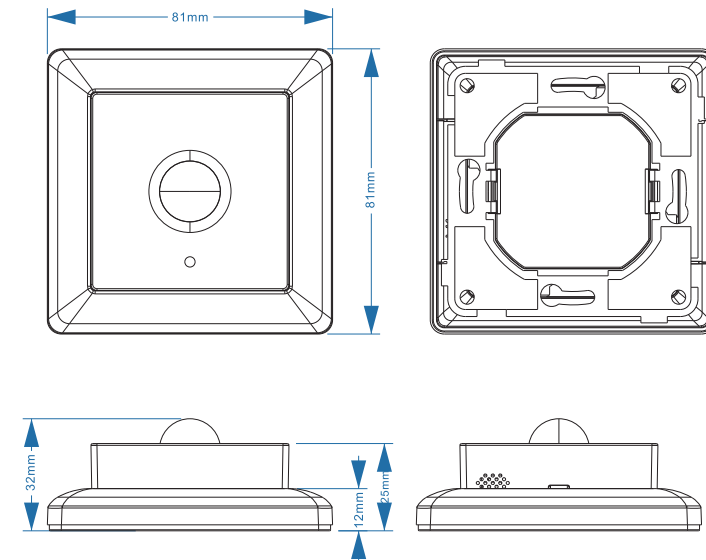

Zigbee 4 In 1 Multi Sensor



Parameters

Physical Information

Dimensions	55.5*55.5*23.7mm
Material / Color	ABS / White

Electrical Information

Operate Voltage	3VDC (2*AAA Batteries)
Standby Consumption	10uA

Wireless Communication

Radio Frequency	2.4 GHz
Wireless Protocol	Zigbee 3.0
Wireless Range	100 feet (30m) Line of Sight
Radio Certification	CE

Sensing

Motion Sensor Type	PIR sensor
PIR sensor Detection Range	Max. 7 meters
Recommended Installation Height	Wall mount, 2.4 meters
Temperature Range and Precision	-40°C~+125°C, ±0.1°C
Humidity Range and Precision	0 – 100% RH (non-condensing), 3%
Illuminance Measuring Range	0~10000 lux

Environment

Operating Temperature Range	32°F to 104°F / 0°C to 40°C (indoor use only)
Operating Humidity	0-95% (non condensing)
Waterproof Rating	IP20
Safety Certification	CE

LED Indicator Status

Operation Description	LED Status
PIR motion sensor triggered	Flashing once rapidly
Powered on	Staying solid on for 1 second
OTA firmware update	Flashing twice rapidly with 1 second interval
Identify	Flashing slowly (0.5S)

Joining a network (Triple press the button)	Flashing rapidly continuously
Joined successfully	Staying solid on for 3 seconds
Leaving a network or reset (Long press the button)	Flashing slowly (0.5S)
Already in a network (Short press the button)	Staying solid on for 3 seconds
Not in any network (Short press the button)	Flashing three times slowly (0.5S)

Operation

1. Zigbee Network Pairing

Step 1: Remove the device from previous zigbee network if it has already been added to, otherwise pairing will fail. Please refer to the part "Factory Reset Manually".

Step 2: From your ZigBee gateway or hub interface, choose to add device and enter Pairing mode as instructed by the gateway.

Step 3: Method 1: short press the "Prog." Button 3 times continuously within 1.5 seconds, the LED indicator will flash rapidly and enter into network pairing mode (beacon request) which lasts for 60 seconds. Once timeout, repeat this step.

Method 2: make sure the device has not paired to any Zigbee network, reset power of the device by removing the batteries and installing them again, then the device will enter into network pairing mode automatically which lasts for 10 seconds. Once timeout, repeat this step.

Step 4: The LED indicator will stay solid on for 3 seconds if the device is paired to the network successfully, then the device will appear in your gateway's menu and can be controlled through gateway or hub interface.

2. Removing from a Zigbee Network

Press and hold the Prog. button until LED indicator blinks 4 times slowly, then release the button, LED indicator will then stay solid on for 3 seconds to indicate that the device is removed from the network successfully.

Note: the device will be removed from the network and all bindings will be cleared.

3. Factory Reset Manually

Press and hold the Prog. button for over 10 seconds, during the process, the LED indicator will blink slowly at the frequency of 0.5Hz, the LED indicator will stay solid on for 3 seconds which means factory reset successfully, then LED will turn off.

Note: factory reset will remove the device from the network, clear all bindings, restore all parameters to factory default setting, clear all report config settings.

4. Check Whether the Device is Already in a Zigbee Network

Method 1: short press Prog. button, if LED indicator stays solid on for 3 seconds, this means the device has already been added to a network. If LED indicator blinks 3 times slowly, this means the device has not been added to any network.

Zigbee 4 In 1 Multi Sensor



Method 2: reset power of the device by removing the batteries and installing them again, if the LED indicator blinks rapidly, it means the device has not been added to any network. If LED indicator stays solid on for 3 seconds, this means the device has not been added to any network.

5. Wireless Data Interaction

Since the device is a sleep device, it needs to be awakened.

If the device has already been added to a network, when there is a button trigger, the device will be awakened, then if there is no data from the gateway within 3 seconds, the device will go to sleep again.

Zigbee Interface

1. Zigbee application endpoints:

Endpoint	Profile	Application
0(0x00)	0x0000 (ZDP)	ZigBee Device Object (ZDO) – standard management features
1(0x01)	0x0104 (HA)	Occupancy Sensor, power, OTA, DeviceID = 0x0107
2(0x02)	0x0104 (HA)	IAS Zone(), DeviceID = 0x0402
3(0x03)	0x0104 (HA)	Temperature Sensor, DeviceID = 0x0302
4(0x04)	0x0104 (HA)	Humidity Sensor, DeviceID = 0x0302
5(0x05)	0x0104 (HA)	Light Sensor, DeviceID = 0x0106

1.1 Application Endpoint #0 –ZigBee Device Object

- Application profile Id 0x0000
- Application device Id 0x0000
- Supports all mandatory clusters

1.2 Application Endpoint #1 –Occupancy Sensor

Cluster	Supported	Description
0x0000	server	Basic Provides basic information about the device, such as the manufacturer ID, vendor and model name, stack profile, ZCL version, production date, hardware revision etc. Allows a factory reset of attributes, without the device leaving the network.
0x0001	server	Power Configuration Attributes for determining detailed information about a device's power source(s) and for configuring under/over voltage alarms.
0x0003	server	Identify Allows to put the endpoint into identify mode. Useful for identifying/locating devices and required for Finding & Binding.

0x0009	server	Alarms
0x0019	Client	OTA Upgrade Pull-oriented firmware upgrade. Searches the network for mating servers and allows the server to control all stages of the upgrade process, including which image to download, when to download, at what rate and when to install the downloaded image.
0x0406	server	Occupancy Sensing Mainly used based on PIR sensor
0x0500	server	IAS Zone Mainly used based on PIR sensor

1.2.1 Basic -0x0000 (Server)

Attributes Supported:

Attribute	Type	Description
0x0000	INT8U, read-only,	ZCLVersion 0x03
0x0001	INT8U, read-only,	ApplicationVersion This is the software version number of the application
0x0002	INT8U, read-only,	StackVersion
0x0003	INT8U, read-only,	HWVersion Hardware version 1
0x0004	string, read-only,	ManufacturerName "Sunricher"
0x0005	string, read-only,	ModelIdentifier When Power up, device will broadcast
0x0006	string, read-only,	DateCode NULL
0x0007	ENUM8, read-only	PowerSource Power supply type of the device, 0x03 (battery)
0x0008	ENUM8, read-only	GenericDevice-Class 0XFF
0x0009	ENUM8, read-only	GenericDevice-Type 0XFF

Zigbee 4 In 1 Multi Sensor



0x000A	octstr read-only	ProductCode 00
0x000B	string, read-only	ProductURL NULL
0x4000	string, read-only	Sw build id 6.10.0.0_r1

Proprietary Attributes:

Attribute	Type	Manufacturer Code	Description
0x1000	INT16U, reportable	0x1224	Scan and read the cycle of temperature, humidity and brightness sensors. Unit: s Range: 10~65535, default value is 60s Note: If the configured time is too short, the power consumption will be higher, and the battery will be reduced.

Command supported:

Command	Description
0x00	Reset to Factory Defaults Command On receipt of this command, the device resets all the attributes of all its clusters to their factory defaults. Note that networking functionality, bindings, groups, or other persistent data are not affected by this command.

1.2.2 Power Configuration-0x0001(Server)

Attributes Supported:

Attribute	Type	Description
0x0020	Int8u, read-only, reportable	BatteryVoltage Current device battery power, unit is 0.1V Min interval: 1s, Max interval: 28800s(8 hour), reportable change: 2 (0.2V)
0x0021	Int8u, read-only, reportable	BatteryPercentageRemaining Remaining battery power percentage, 1-100 (1%-100%) Min interval: 1s, Max interval: 28800s(8 hour), reportable change: 5 (5%)
0x0035	MAP8, reportable	BatteryAlarmMask Bit0 enables BatteryVoltageMinThreshold alarm
0x003e	map32, read-only, reportable	BatteryAlarmState Bit0, Battery voltage too low to continue operating the device 's radio (i.e., BatteryVoltageMinThreshold value has been reached)

1.2.3 Identify-0x0003 (Server)

Attributes Supported:

Attribute	Type	Description
0x0000	Int16u	Identify time

Sever can receive the following commands:

CmdID	Description
0x00	Identify
0x01	IdentifyQuery

Sever can generate the following commands:

CmdID	Description
0x00	IdentifyQueryResponse

1.2.4 OTA Upgrade-0x0019 (Client)

When the device has joined a network it will automatically auto scan for a OTA upgrade server in the network. If it finds a server an auto bind is created and ones every 10mins it will automatically send its "current file version" to the OTA upgrade server. It is the server that initiates the firmware upgrade process.

Attributes Supported:

Attribute	Type	Description
0x0000	EUI64, read-only	UpgradeServerID 0xffffffffffffff, is an invalid IEEE address.
0x0001	Int32u, read-only	FileOffset The parameter indicates the current location in the OTA upgrade image. It is essentially the (start of the) address of the image data that is being transferred from the OTA server to the client. The attribute is optional on the client and is made available in a case where the server wants to track the upgrade process of a particular client.
0x0002	Int32u, Read-only	OTA Current File Version When Power up, device will broadcast
0x0006	enum8, read-only	ImageUpgradeStatus The upgrade status of the client device. The status indicates where the client device is at in terms of the download and upgrade process. The status helps to indicate whether the client has completed the download process and whether it is ready to upgrade to the new image.

Zigbee 4 In 1 Multi Sensor



1.2.5 Occupancy Sensing-0x0406(Server)

Attributes Supported:

Attribute	Type	Description
0x0000	MAP8, read-only reportable	Occupancy
0x0001	ENUM8, read-only	Occupancy Sensor Type The type is always 0x00 (PIR)
0x0002	MAP8, read-only	Occupancy Sensor Type Bitmap The type is always 0x01 (PIR)
0x0010	int16U, reportable read-only	PIROccupiedToUnoccupiedDelay No trigger during this period since last trigger, when time expires, Unoccupied will be marked. Value range is 30~28800, unit is S, default value is 60s.

Proprietary Attributes:

Attribute	Type	Manufacturer Code	Description
0x1000	ENUM8, reportable	0x1224	PIR Sensor Sensitivity Default value is 15. 0: disable PIR 8~255: enable PIR, corresponding PIR sensitivity, 8 means the highest sensitivity, 255 means the lowest sensitivity.
0x1001	Int8u, reportable	0x1224	Motion detection blind time PIR sensor is "blind" (insensitive) to motion after last detection for the amount of time specified in this attribute, unit is 0.5S, default value is 15. Available settings: 0-15 (0.5-8 seconds, time [s] = 0.5 x (value+1))
0x1002	ENUM8, reportable	0x1224	Motion detection - pulse counter This attribute determines the number of moves required for the PIR sensor to report motion. The higher the value, the less sensitive the PIR sensor is. It is not recommended to modify this parameter settings! Available settings: 0~3 0: 1 pulse 1: 2 pulses (default value) 2: 3 pulses 3: 4 pulses

0x1003	ENUM8, reportable	0x1224	PIR sensor trigger time interval It is not recommended to modify this parameter settings! Available settings: 0~3 0: 4 seconds 1: 8 seconds 2: 12 seconds 3: 16 seconds (default value)
--------	----------------------	--------	---

1.2.6 Alarm-0x0009(Server)

Please set a valid value of BatteryAlarmMask of Power Configuration.

The Alarm Server cluster can generate the following commands:

CmdID	Description
0x00	Alarm Alarm code: Identifying code for the cause of the alarm, as given in the specification of the cluster whose attribute generated this alarm.

Power Configuration, alarm code: 0x10.

BatteryVoltageMinThreshold or BatteryPercentageMinThreshold reached for Battery Source

1.3 Application Endpoint #3-IAS Zone

1.3.1 IAS Zone-0x0500(Server)

Attributes Supported:

Attribute	Type	Description
0x0000	ENUM8, read-only	Zone State Not enrolled or enrolled
0x0001	ENUM16, read-only	Zone Type is always 0x0D (Motion sensor)
0x0002	MAP16, read-only	Zone Status Bit0 support (alarm1)
0x0010	EUI64,	IAS_CIE_Address
0x0011	Int8U,	Zone ID 0x00 – 0xFF Default 0xff

The IAS Zone Server cluster can generate the following commands:

Zigbee 4 In 1 Multi Sensor



CmdID	Description
0x00	Zone Status Change Notification Zone Status Extended Status Zone ID Delay
0x01	Zone Enroll Request Zone Type Manufacturer Code

The IAS Zone Server cluster can receive the following commands:

CmdID	Description
0x00	Zone Enroll Response Zone Type Manufacturer Code

1.4 Application Endpoint #3—Temperature Sensor

Cluster	Supported	Description
0x0000	server	Basic Provides basic information about the device, such as the manufacturer ID, vendor and model name, stack profile, ZCL version, production date, hardware revision etc. Allows a factory reset of attributes, without the device leaving the network.
0x0003	server	Identify Allows to put the endpoint into identify mode. Useful for identifying/locating devices and required for Finding & Binding.
0x0402	server	Temperature Measurement Temperature sensor

1.4.1 Temperature Measurement-0x0402 (Server)

Attributes Supported:

Attribute	Type	Description
0x0000	Int16s, read-only, reportable	Measuredvalue Temperature value, unit is 0.01°C Report, default: Min interval: 1s Max interval: 3600s (60mins). This value is recommended not to be less than 60s, otherwise the PIR may be accidentally triggered easily. Reportable change: 100 (1°C), only judge when the device is awakened, for instance, PIR triggered, the button is pressed, scheduled awakening etc.

0x0001	Int16s, read-only	MinMeasuredValue 0xF060 (-40°C)
0x0002	Int16s, read-only	MaxMeasuredValue 0x30D4 (125°C)

Proprietary Attributes:

Attribute	Manufacturer Code	Type	Description
0x1000	0x1224	Int8s, reportable	Temperature Sensor Compensation -5~+5, unit is °C

1.5 Application Endpoint #4—Humidity Sensor

Cluster	Supported	Description
0x0000	server	Basic Provides basic information about the device, such as the manufacturer ID, vendor and model name, stack profile, ZCL version, production date, hardware revision etc. Allows a factory reset of attributes, without the device leaving the network.
0x0003	server	Identify Allows to put the endpoint into identify mode. Useful for identifying/locating devices and required for Finding & Binding.
0x0405	server	Relative Humidity Measurement Humidity sensor

1.5.1 Relative Humidity Measurement-0x0405 (Server)

Attributes Supported:

Attribute	Type	Description
0x0000	Int16u, read-only, reportable	Measuredvalue unit is 0.01 percent 0x0000 to 0x2710 represent relative humidity from 0% to 100% 0xFFFF indicates an invalid measurement Report, default: Min interval: 1s Max interval: 3600s (60mins). This value is recommended not to be less than 60s, otherwise the PIR may be accidentally triggered easily. Reportable change: 500 (5%), only judge when the device is awakened, for instance, PIR triggered, the button is pressed, scheduled awakening etc.
0x0001	Int16u, read-only	MinMeasuredValue 0

0x0002	Int16u, read-only	MaxMeasuredValue 10000
--------	----------------------	----------------------------------

Proprietary Attributes:

Attribute	Manufacturer Code	Type	Description
0x1000	0x1224	Int8s, reportable	Humidity Sensor Compensation -5~+5, unit is 1 percent

1.6 Application Endpoint #5–Light Sensor

Cluster	Supported	Description
0x0000	server	Basic Provides basic information about the device, such as the manufacturer ID, vendor and model name, stack profile, ZCL version, production date, hardware revision etc. Allows a factory reset of attributes, without the device leaving the network.
0x0003	server	Identify Allows to put the endpoint into identify mode. Useful for identifying/locating devices and required for Finding & Binding.
0x0400	server	Illuminance Measurement Light sensor

1.6.1 Illuminance Measurement-0x0400 (Server)

Attributes Supported:

Attribute	Type	Description
0x0000	Int16u, read-only, reportable	Measuredvalue 0xFFFF indicates an invalid measurement Report, default: Min interval: 1s Max interval: 3600s (60mins). This value is recommended not to be less than 60s, otherwise the PIR may be accidentally triggered easily. Reportable change: 16990 (50lux), please be noted that the device will report according to lux unit value change. For instance, when Measuredvalue=21761 (150lx) drops down to 20001 (50lux), the device will report, instead of reporting when the values drops down to 4771=(21761-16990). Only judge when the device is awakened, for instance, PIR triggered, the button is pressed, scheduled awakening etc.

0x0001	Int16u, read-only	MinMeasuredValue 1
0x0002	Int16u, read-only	MaxMeasuredValue 40001

Proprietary Attributes:

Attribute	Manufacturer Code	Type	Description
0x1000	0x1224	Int8U, reportable	Light Intensity Compensation Ratio Range: 1~100, unit is 0.1 times, default value is 10. For example, if this value is 12, then Measuredvalue=Measure*1.2

Detection Range

Detection range of the Motion Sensor is shown below. Actual range of the Sensor can be influenced by environmental conditions.

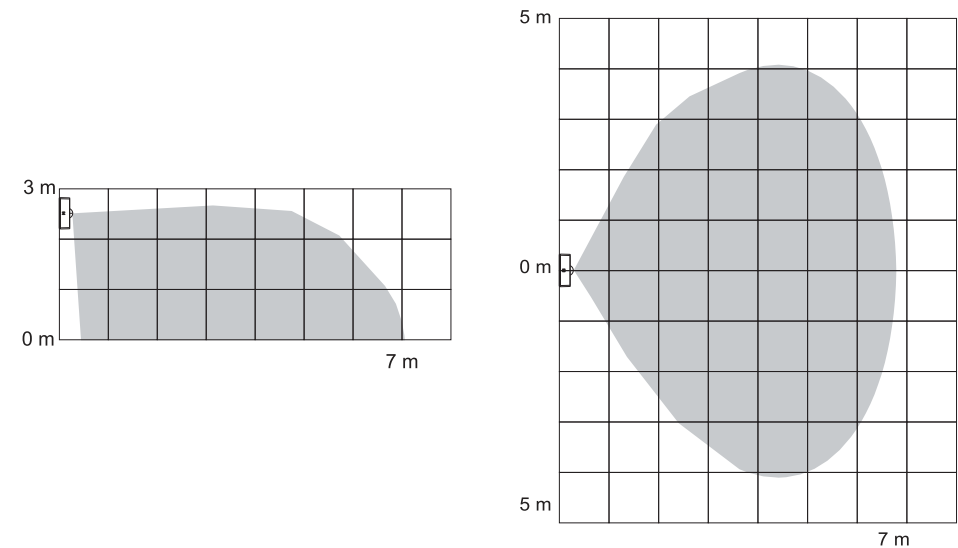

Physical Installation

Method 1: Stick 3M glue on the back of the bracket and then stick the bracket to the wall

Method 2: Screw the bracket to the wall

After the bracket is fixed, clip the frame and control part to the bracket in sequence

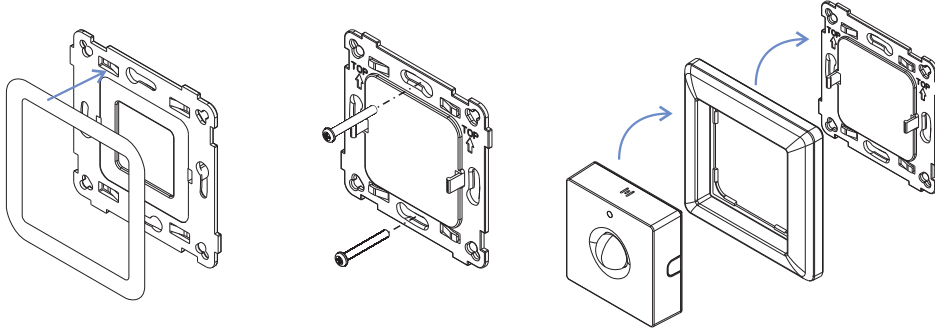

Installation Precautions

- Avoid areas with frequent temperature changes: Keep away from air conditioners, fans, refrigerators, ovens, and other objects that cause rapid temperature changes. The detection effectiveness of PIR motion sensors is closely related to temperature fluctuations, and vents or heat sources can lead to false alarms.
- Avoid areas with significant air flow.
- Avoid facing glass doors and windows directly: 1) Do not face glass doors and windows directly to avoid interference from strong light. 2) Avoid complex environments outside doors and windows, such as direct sunlight, crowds, and moving vehicles.
- Avoid installing opposite large, constantly moving objects: Large objects with significant motion can cause sudden changes in airflow within the detection area, leading to false alarms. Outdoor PIR motion sensors should not be installed opposite large trees or tall bushes.
- Avoid areas with screens, furniture, large potted plants, or other obstacles within the detection range.
- Avoid areas exposed to direct sunlight.