



**■ Feature**

- Powered by high output 3030 LED.
- Constant current.
- Elliptical 10x65° optic lens.
- 20 pcs per string.
- CE, RoHS, UL, TUV, BIS, CB and LM-80 certified.

**■ Application**

- Light coverage: up to 1.5M
- Apply to 8-20 cm depth double-sided light box at airports, metros, banks, buildings and shopping malls, etc.

**■ Parameters**

Items	Parameters
Part Number	EV-SLEL01LBY-CW
CCT (K)	7000K
Beaming Angle (°)	10*65°
CRI (Ra)	≥75
Luminous Flux (lm)	125
Voltage (V)	DC12
Power (W)	1.32
Driving Method	Constant Current
Dimension (mm)	43*23*11.6
Working Tem. (°C)	-25 ~ +60
Storage Tem. (°C)	-25 ~ +70
Protection Grade	IP65

■ Dimension (Unit:mm)

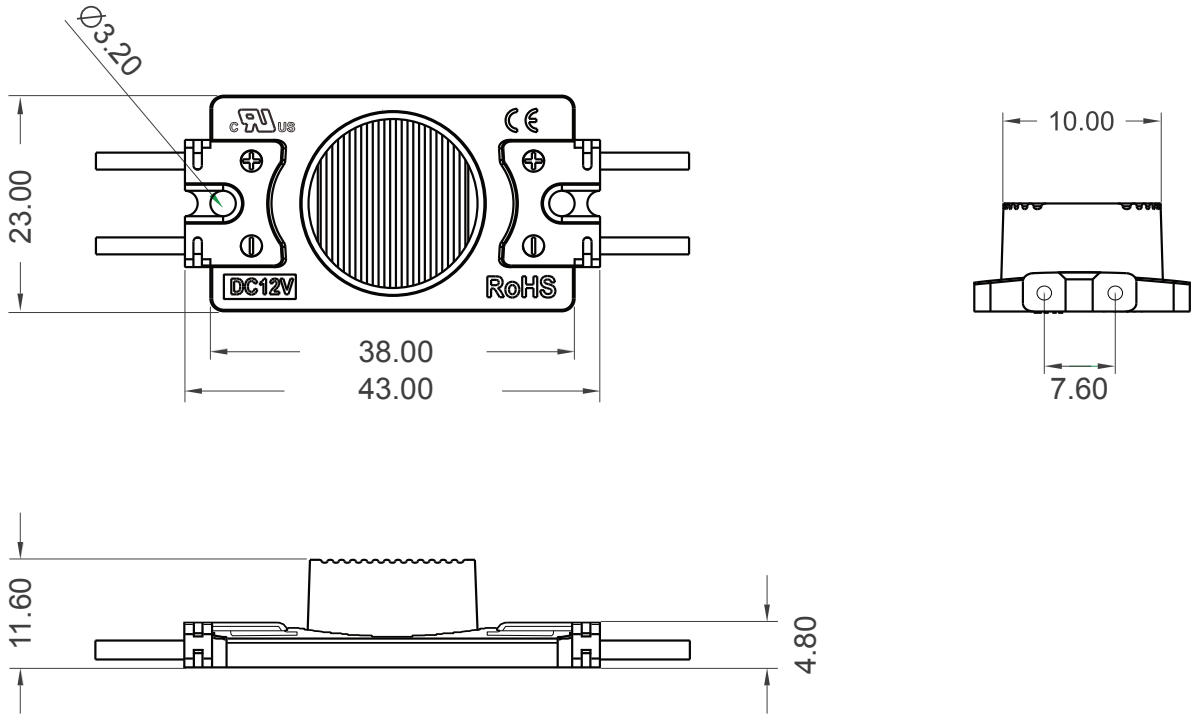

■ Beaming Angle

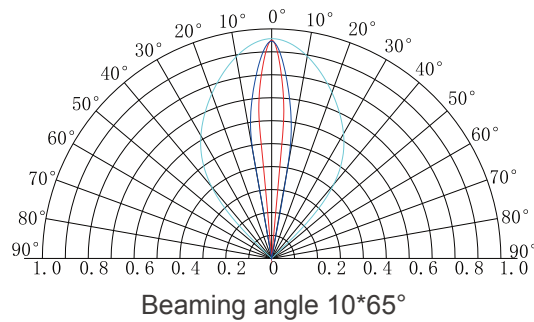

■ **Reference Scheme**

Part Number	Depth(mm)	Max. Spacing(mm)	Density(pcs/m <sup>2</sup> )	Illumination(lux)
EV-SLEL01LBY-CW	Dz=120	1000*1000	30	650-700
	Dz=150	1000*1000	30	600-650
	Dz=180	1000*1000	30	500-600
	Dz=200	1000*1000	30	500-550

**Remark:**

- 01. The transmittance of the advertising fabric was 32%.
- 02. The above data is for reference only.

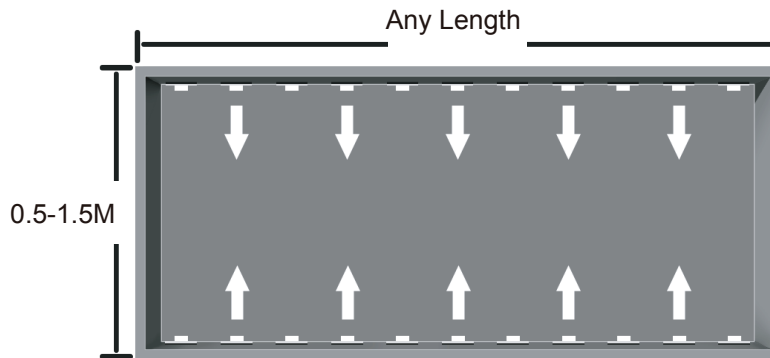

■ **Wire Connection**

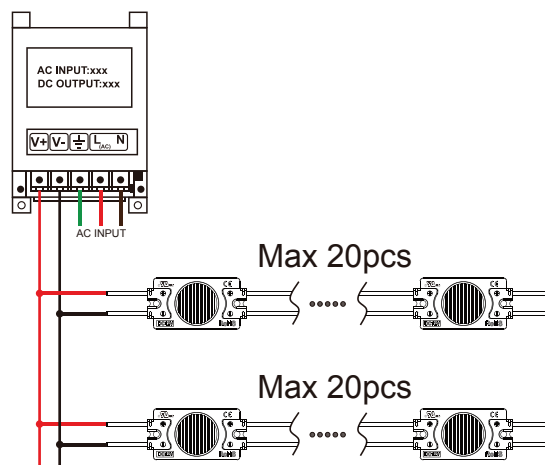

## ■ Packing

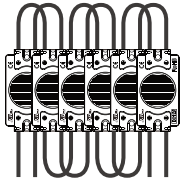

20pcs per string

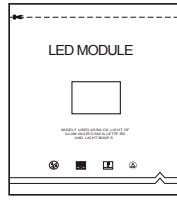

100pcs in an anti-static bag

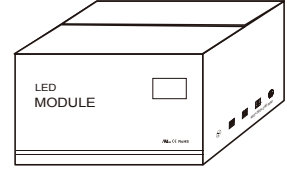

1500pcs per carton

## ■ Packing Specification

- Antistatic bag adopted
- Packing information

Part Number	EV-SLEL01LBY-CW
Carton Dimension (mm)	490*450*220
Bags Per Carton	15
Quantity Per Carton (pcs)	1500
Net Weight (kg)	12.6(1±10%)
Gross Weight (kg)	13.7(1±10%)

Due to the packing manner difference, please adhere to the original products in case of discrepancy found between the picture and actual product.

## ■ Self-provided tools & material

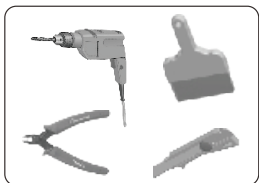

Dust brush, cutter, pencil, wire stripper, and drill



Wire Connector (Standard)



Screw

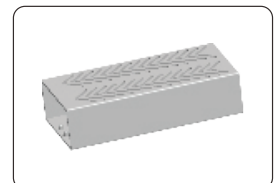

Power Supply

■ **Installation Guidance**

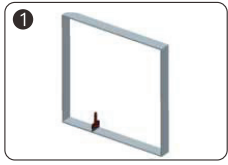

- Clean inside the light box.

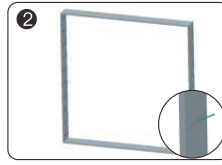

- Determine the appropriate layout.

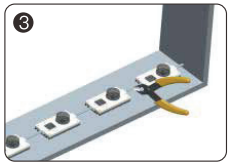

- Remove the unneeded modules.
- ⚠ Note: Cut in the middle position of the wires between modules.



- Strip the end wire for 10mm and cap with the wire connector. Waterproof and anti-corrosion must be done on the connectors.

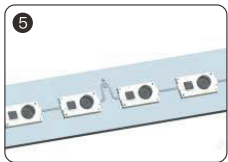

- Connect the led modules with wire connectors. Avoid connecting more than 20pcs in series connection.



- Adjust modules to the optimal position and secure with screws.



- Drill a hole for connecting power cable. Fixation and protection for the cable must be done on the hole.
- ⚠ Note: Avoid breaking the light box in drilling the hole.

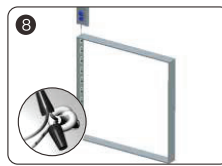

- Connect to power supply and make sure that the polarity for connection is correct.

■ **Instructions**

01. When installing the product, please switch off the power.
02. Please use constant voltage power supply and leave 20% or more balance of its total power.
03. Make isolation and corrosion prevention on all wiring points and wire ends.
04. The maximum series connection quantity for EV-SLEL01LBY-CW is 20 pcs , please do not exceed this number.
05. The products can be installed by screws, rivets as well as silicon gel, while please do not use Acidic or alkaline adhesive.
06. The high power LEDs generates more heat, so please install the products on the surface of material with good heat dissipation such as metallic or aluminium panel
07. For single side light box, in order to get better and even lighting effect, you can put the products more closer to unilluminated back and attach white reflective poly sheet or sheet with similar function on the inner back.
08. Initial location with 3M tape, then secure with screws.

## ■ Declaration

01. Warranty: 5 years.
02. In order to ensure the safety, the broken wires need to be replaced by the manufacturer or the service agent, or by the staff with the similar qualification.
03. The given data in the specification was based on the laboratory testing, there may be discrepancy found in the actual products.
04. The given drawings in the specification are only for reference, there may be discrepancy found in the actual products.
05. The products are subject to change without prior notification.