



Feature

- Powered by high output 2835 LED.
- Constant Voltage.
- Diamondback 180*140° optic lens.
- 40 pcs per string.

Application

- Apply to 3-8 cm depth illuminated letters or light boxes.

Parameters

Items	Parameters		
Part Number	EV-BLML01LBY-CW	EV-BLML02LBY-CW	EV-BLML03LBY-CW
CCT (K)	7000K	7000K	7000K
Beaming Angle (°)	180*140°	180*140°	180*140°
CRI (Ra)	≥80	≥80	≥80
Luminous Flux (lm)	29	55	85
Voltage (V)	DC12	DC12	DC12
Power (W)	0.24	0.48	0.72
Driving Method	Constant Voltage	Constant Voltage	Constant Voltage
Dimension (mm)	14*9*8.8	26*9*9	38*9*9
Working Tem. (°C)	-25 ~ +60	-25 ~ +60	-25 ~ +60
Storage Tem. (°C)	-25 ~ +70	-25 ~ +70	-25 ~ +70
Protection Grade	IP66	IP66	IP66

■ **Dimension (Unit:mm)**

EV-BLML01LBY-CW

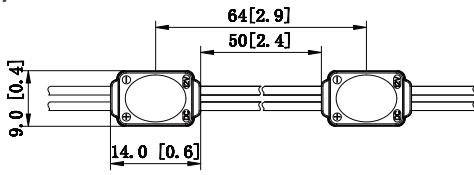

EV-BLML02LBY-CW

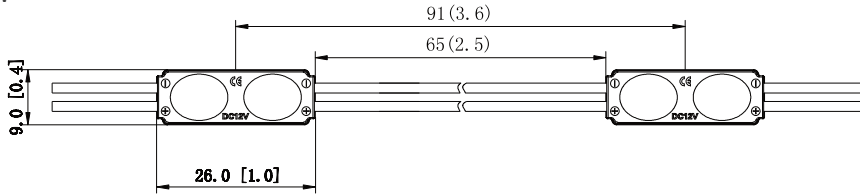

EV-BLML03LBY-CW

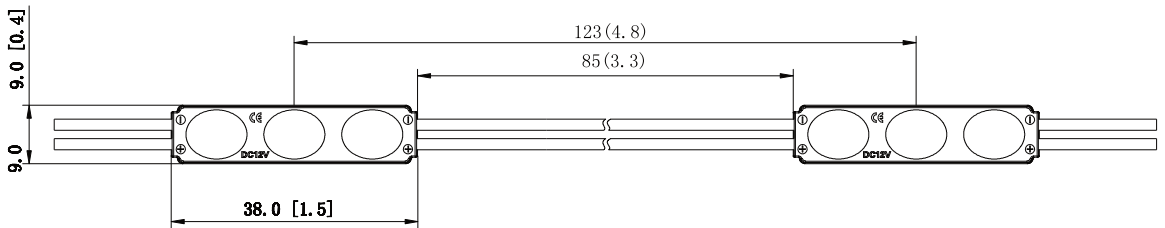

■ **Beaming Angle**

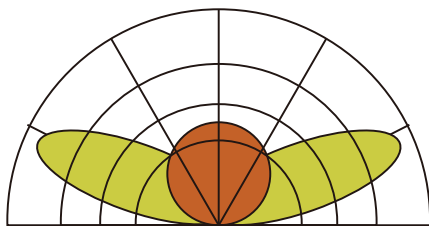

beaming angle 180*140°

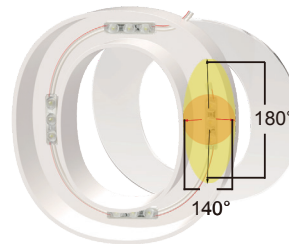

■ Reference Scheme

Part Number	Depth (mm)	Size (mm)	Distance (mm)	Quantity (pcs)	Density (pcs/m ²)	Power per (m ²)	Illumination (lux)
EV-BLML01LBY-CW	20	120*120*20	30	12	50	12	5430
	30	140*140*30	40	12	50	12	5300
	40	160*160*40	60	12	50	12	4200
	50	180*180*50	70	12	50	12	3900
	60	200*200*60	50	12	50	12	3700

Part Number	Depth (mm)	Size (mm)	Distance (mm)	Quantity (pcs)	Density (pcs/m ²)	Power per (m ²)	Illumination (lux)
EV-BLML02LBY-CW	20	120*120*20	42	10	42	20	12000
	30	140*140*30	50	12	50	24	10500
	40	160*160*40	52	12	50	24	7100
	50	180*180*50	52	15	63	30	6200
	60	200*200*60	52	18	75	36	6200

Part Number	Depth (mm)	Size (mm)	Distance (mm)	Quantity (pcs)	Density (pcs/m ²)	Power per (m ²)	Illumination (lux)
EV-BLML03LBY-CW	20	120*120*20	50	8	33	24	12000
	30	140*140*30	58	10	42	30	10500
	40	160*160*40	70	10	42	30	7100
	50	180*180*50	70	13	54	59	6200
	60	200*200*60	70	18	75	54	6200

Remark:

01. The acrylic plate in the case is 3mm thickness, and the light transmittance is 54.4%.
02. The illumination above is the minimum data when evenly lighted.
03. The above data is for reference only.

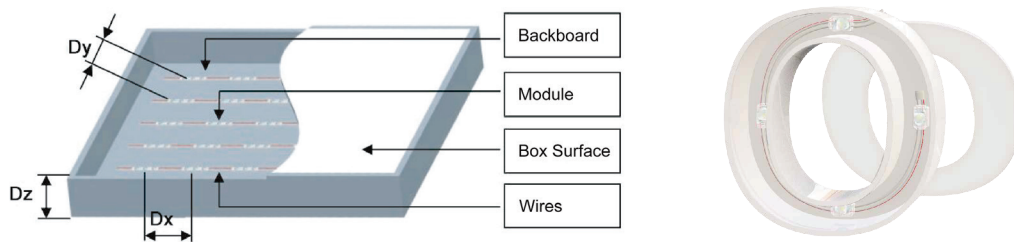

■ Wire Connection

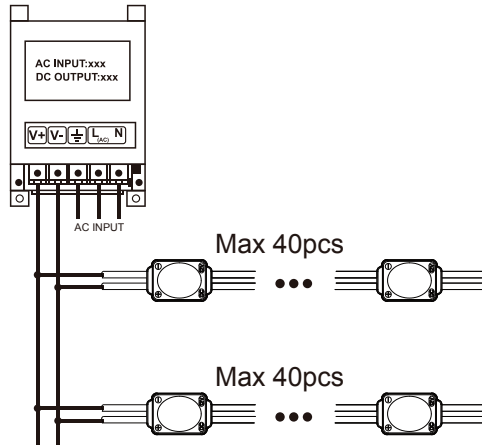

■ Packing

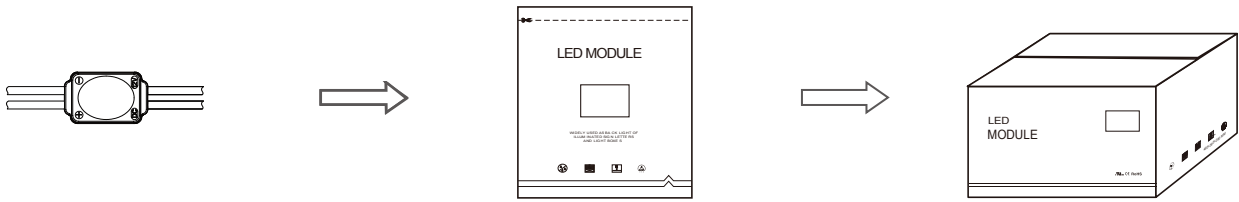

EV-BLML01LBY-CW 40 pcs per string
EV-BLML02LBY-CW 40 pcs per string
EV-BLML03LBY-CW 40 pcs per string

320 pcs in an antistatic bag
 200 pcs in an antistatic bag
 160 pcs in an antistatic bag

4800 pcs per carton
 3000 pcs per carton
 2400 pcs per carton

■ Packing Specification

- Antistatic bag adopted
- Packing information

Part Number	EV-BLML01LBY-CW	EV-BLML02LBY-CW	EV-BLML03LBY-CW
Carton Dimension (mm)	490*450*220	490*450*220	490*450*220
Bags Per Carton	15	15	15
Quantity Per Carton (pcs)	4800	3000	2400
Net Weight (kg)	8.2(1±10%)	8.16(1±10%)	9.53(1±10%)
Gross Weight (kg)	9.3(1±10%)	9.26(1±10%)	10.63(1±10%)

Due to the packing manner difference, please adhere to the original products in case of discrepancy found between the picture and actual product.

■ Self-provided tools & material

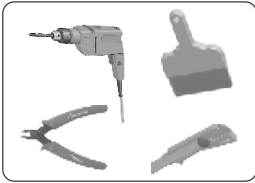

Dust brush, cutter, pencil, wire stripper, and drill



Wire Connector (Standard)

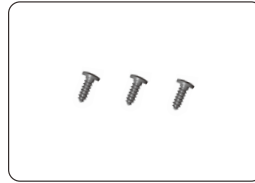

Screw

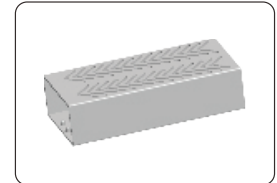

Power Supply

■ Installation Guidance

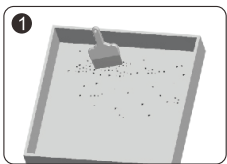

- Clean inside the light box.

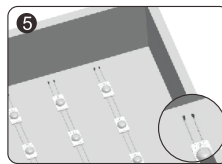

- Strip the end wire for 10mm and cap with the wire connector. Waterproof and anti-corrosion must be done on the connectors.

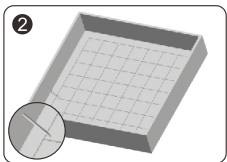

- Determine the appropriate layout.

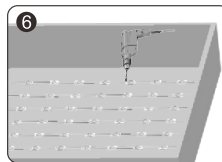

- Locate modules in the optimal position and secure with screws or neutral glass cement, which should be applied at the edge of the modules.
- ⚠ Note: Avoid breaking the module and wire when fixing with a drill.

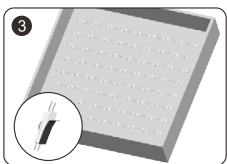

- Peel tape backing and stick modules into place.

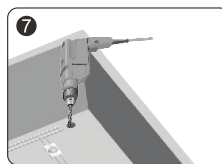

- Drill a hole for connecting power cable. Fixation and protection for the cable must be done on the hole.
- ⚠ Note: Avoid breaking the light box in drilling the hole.

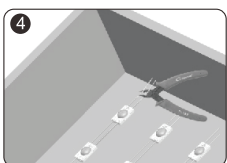

- Remove the unneeded modules.
- ⚠ Note: Cut in the middle position of the wires between modules.

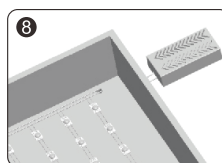

- Connect to the power cable and make sure that the polarity for connection is correct.
- ⚠ Note: Red wire is positive and black wire is negative.

■ Instructions

01. Disassembling or modifying the product is not allowed.
02. Installation with power on is not allowed.
03. Any organic solvent chemical is not allowed.
04. Acidic or alkaline adhesive is not allowed when install, neutral glass cement could be used for installation purpose, make it drying in open environment for four hours.
05. Isolation and corrosion prevention on all wiring points and wire ends.
06. Make sure the power wire is thick enough and ensure the voltage and connections are connected correctly before power on.
07. This product should be used in a sign, do not expose it in opening site.
08. Installation, maintaining should be done by professional staff.
09. 40 pcs in a serial connection maximum.
10. The power wire between power supply and module should be less than two meters to keep the same brightness on all parts.
11. Attached with 3M tape.

■ Declaration

01. Warranty: 5 years.
02. In order to ensure the safety, the broken wires need to be replaced by the manufacturer or the service agent, or by the staff with the similar qualification.
03. The given data in the specification was based on the laboratory testing, there may be discrepancy found in the actual products.
04. The given drawings in the specification are only for reference, there may be discrepancy found in the actual products.
05. The products are subject to change without prior notification.